



***SMDC-16***  
**INSTALLATION &**  
**OPERATION MANUAL**

SMDC-16 Digital Control Communicator  
and  
SMPC-32 Personal Control

# Table of Contents

<i>System Description</i>	3
---------------------------	---

## Hardware

<i>Control Panel Terminal Layout Diagram</i>	4
<i>Wiring Data</i>	5 - 9
<i>RJ-31X Wiring Diagram</i>	9
<i>Expansion Board Data</i>	10
<i>Expansion Board Wiring Diagram</i>	10
<i>Control Panel Hardware</i>	11
<i>Battery Calibration</i>	11
<i>Battery Calculation</i>	12

## Keypads

<i>Keypad Function Diagram</i>	13
<i>Keypad Wiring Diagram</i>	14
<i>Keypad Voltmeter</i>	14

<i>PGM Trigger Wiring</i>	15
---------------------------	----

## Underwrites Laboratory

<i>Appendix A</i>	15
<i>Appendix B</i>	16
<i>UL Information Addendum</i>	16
<i>Communication Requirements</i>	17
<i>Grades of Service</i>	17
<i>UL Listings</i>	17
<i>Grade A Local Mercantile Installation Requirements</i>	17
<i>Current Rating Chart</i>	17
<i>Walk Tests</i>	18
<i>Fire Walk Test</i>	18
<i>Walk Test History</i>	18
<i>UL Compliance Verification Chart</i>	19
<i>Compatible 2 Wire Smoke Detectors</i>	19
<i>Compatible 4 Wire Smoke Detectors</i>	19
<i>Program Requirements</i>	19

<i>Optex Inc. Warranty</i>	20
----------------------------	----

# General System Description

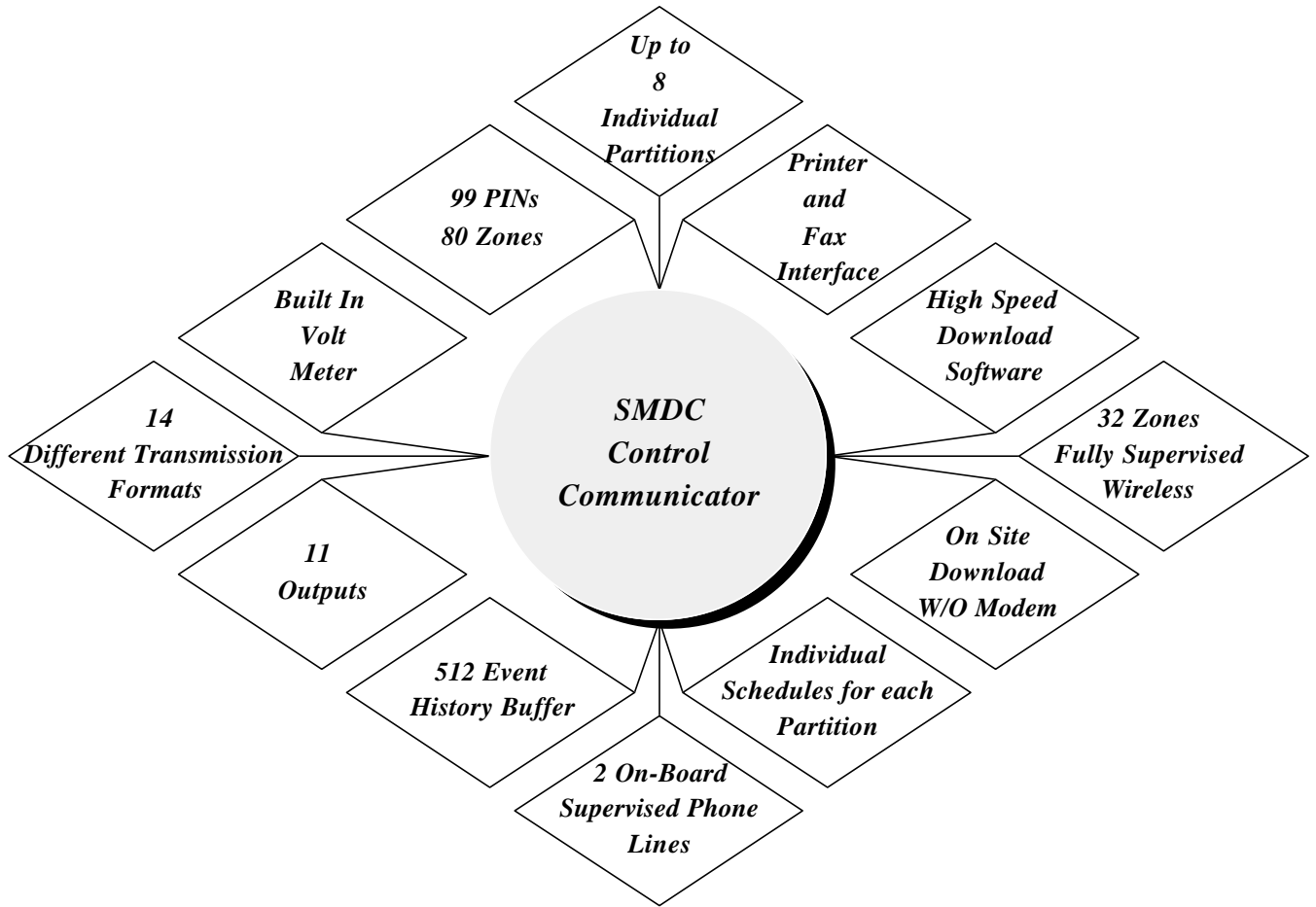

# Terminal Layout Diagram

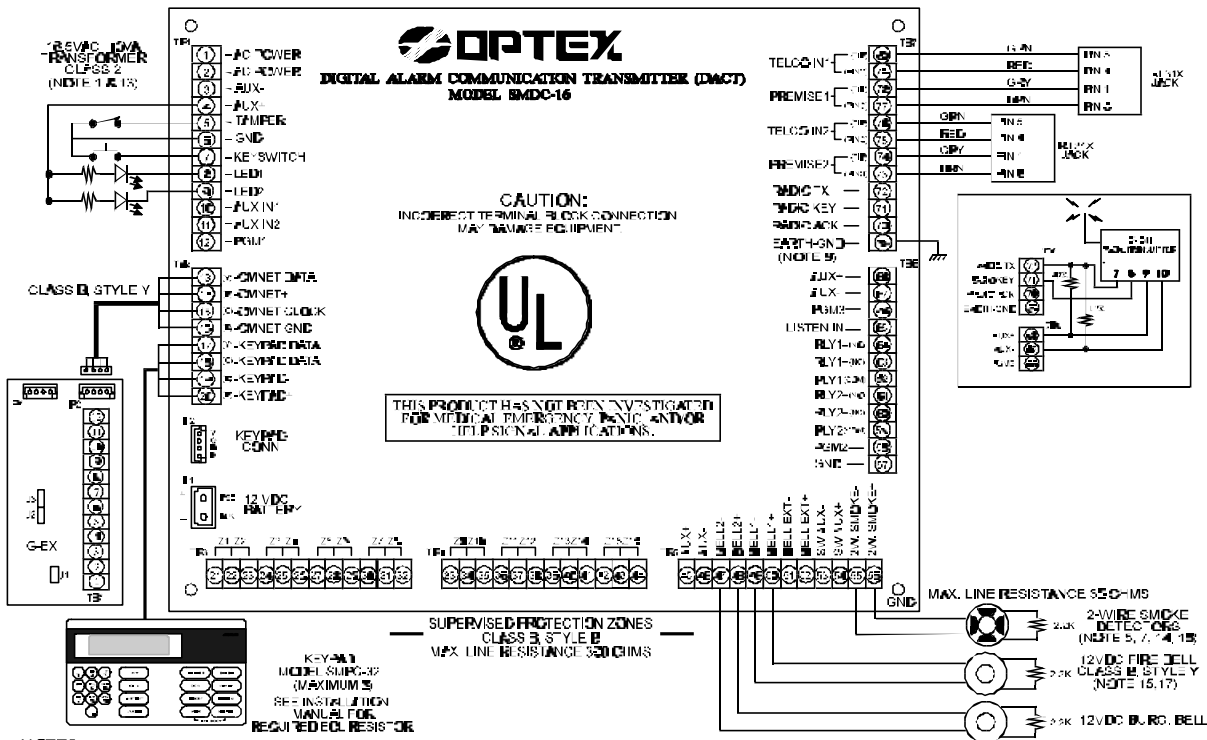

**NOTES:**

1. UL LISTED ENCLOSURE FOR CLASS 2 TRANSFORMER
2. MAXIMUM COMBINED POWER AVAILABLE ON PANEL IS 1.4 AMP INCLUDING TERMINALS 3, 4, 14, 16, 18, 20, 46-50, 53, 54, 57, 60.
3. THIS PANEL IS POWER LIMITED.
4. FIRE REL (TERMINALS 49 & 50) 2 WIRE SMOKE DETECTOR CIRCUIT (TERMINALS 55 & 56) REQUIRE 2.2K OHM 1/2 WATT FIRE CELL ASSY. OPTEX MODEL PART NUMBER 5090-0265.
5. THE OPERATING VOLTAGE RANGE FOR 2 WIRE SMOKE DETECTOR IS 9.6V TO 13.5V.
6. FROM 1, 2, AND 3 ARE OPEN COLLECTOR OUTPUTS WHICH GO LOW WHEN ACTIVATED. MAXIMUM CURRENT IS 50mA.
7. 2-WIRE SMOKE DETECTOR LISTING: MAXIMUM 10 DETECTORS ON LOOP. DETECTION SYSTEM DC261/2501-4 DETECTOR IDENTIFIER-A SYSTEM SENSOR 2400/2401-4 DETECTOR IDENTIFIER-A SYSTEM SENSOR 2300/2301-4 DETECTOR IDENTIFIER-A SYSTEM SENSOR 4250/4251-4 DETECTOR IDENTIFIER-BIGA.
8. CONNECT EAR HORN TO TERMINAL 35.
9. A UL LISTED TAMPER SWITCH SHOULD BE USED FOR UL COMMERCIAL BURGLAR ALARM APPLICATIONS.
10. THE UNIT SHOULD BE TESTED WEEKLY.
11. USE 2.2K OHM 1/2 WATT RESISTOR FOR BURGALAR ZONES THAT REQUIRE END OF LINE SUPERVISION.
12. CENTRAL PANEL ID: 50155 (BMD-16).
13. DO NOT CONNECT TO A CENTRAL CONTROLLED BY SWITCH.
14. PANEL CAN NOT DETECT MORE THAN ONE SMOKE DETECTOR IN ALARM CONDITION.

15. IF USING EXTERNAL POWER SUPPLY TO DRIVE FIRE BELL, CONNECT 12 V DC 24 V, 5 AMP MAX UL LISTED EXTERNAL POWER SUPPLY TO TERMINALS 51 & 52.
16. 2-WIRE SMOKE DETECTORS OF DIFFERENT MODELS CAN NOT BE MIXED & MATCHED.
17. USE BELLS MANUFACTURED BY WHEELLOCK MODELS M3-C6, 2R, M3-C10-12-R, M3-C6-2-W-H-F, M3-C6-3-D-12-W-H-F OR USE AMSEC MODEL M33 10B PV4 12.
18. USE UL LISTED LIMITED ENERGY CABLE FOR CONNECTIONS.
19. FOR INSTALLATION INSTRUCTIONS, SEE A1 IN EACH MANUAL, PART NO. 3445-0251 Rev. A4.
20. USE A UL LISTED END OF LINE RELAY FOR 2-WIRE SMOKE DETECTORS.
21. THIS CONTROL UNIT SHOULD BE CHECKED BY A QUALIFIED TECHNICIAN AT LEAST EVERY 3 YEARS.
22. THIS EQUIPMENT SHOULD BE INSTALLED IN ACCORDANCE WITH CHAPTER 2 OF THE NATIONAL FIRE ALARM CODE (NFPA 72-1983) NATIONAL FIRE PROTECTION ASSOCIATION, BOSTON, MASSACHUSETTS. FOR ADDITIONAL INFORMATION DESCRIBING PROPER INSTALLATION, OPERATION, TESTING, MAINTENANCE, EVACUATION PLANNING, AND REPAIR SERVICE IS TO BE PROVIDED WITH THIS EQUIPMENT.
23. MAXIMUM BATTERY CHARGING CURRENT IS 700mA.
24. TYPE OF SERVICE: AUTOMATIC FIRE ALARM, MANUAL FIRE ALARM, WATER FLOW ALARM, SPRINKLER SUPERVISORY.
25. TYPE OF SIGNALING: DIGITAL ALARM COMMUNICATOR TRANSMITTER (IF USING OPTEX SIGNAL MODEL 46-RV1 TRANSMITTER).

U.L. FILE NO. S-1152  
**APPLICABLE U.L. STANDARDS:**  
 UL 123 - HOUSEHOLD BURGLAR ALARM SYSTEM UNITS  
 UL 500 - HOUSEHOLD FIRE WARNING SYSTEM UNITS  
 UL 650 - DIGITAL ALARM COMMUNICATOR SYSTEM UNITS  
 UL 365 - POLICE STATION CONNECTED TO BURGLAR ALARM AND SYSTEMS  
 UL 605 - LOCAL BURGLAR ALARM UNITS AND SYSTEMS  
 UL 1015 - CENTRAL STATION BURGLAR ALARM UNITS  
 UL 684 - SIGNAL SYSTEM CENTER UNITS  
**UL LISTED FOR:**  
 CENTRAL STATION, LOCAL AND PROPRIETARY FIRE ALARM  
 NFPA 72 CHAPTER 2 HOUSEHOLD FIRE WARNING SYSTEMS  
 POLICE STATION CONNECT, GRADE A, MERCANTILE PREMISES  
 AND MERCANTILE SAFE AND VAULT  
 LOCAL, GRADE A, MERCANTILE PREMISES AND MERCANTILE  
 SAFE AND VAULT  
 CENTRAL STATION, GRADE A, B OR C  
 HOUSEHOLD BURGLAR ALARM  
 WHEN INSTALLED IN ACCORDANCE WITH THE REQUIREMENTS  
 OUTLINED IN THE SIGNAL OPERATION AND INSTALLATION MANUAL  
 (OPTEX PART NUMBER 3445-0251 Rev. A4)

Circuit (Zone)	Control Unit delay, seconds	Smoke detector	
		Model	Delay, seconds
Include detector data or the following or equivalent statement: "The delay (power up) (start-up) time marked on the installation wiring diagram of the smoke detector or on the installed smoke detector(s) is to be used."			

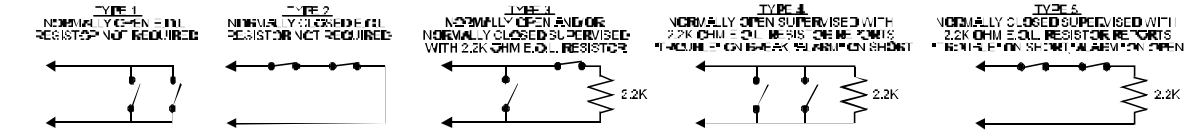

## Wiring Data

Terminals    Description

---

**69**                    *Earth Ground Connection*

- Supervised Earth Ground.
- Always connect Earth Ground first.
- You must use a minimum of 18AWG wire.
- DO NOT connect the Earth Ground to an electrical, telco, or chassis ground.
- Keep the Earth Ground wire run length to a minimum.
- Always touch Ground before performing any work on the control panel.

---

**1 & 2**                *AC Power Input*

- Supervised input.
- 16.5 VAC, 40VA (Basler Electric Model:BE116240CAA) Class 2 plug in transformer.
- Use 18AWG (twisted or zip) wire minimum.
- Keep the wire run as short as possible.
- Test the electrical outlet to verify that it is *unswitched*.
- 17.0 to 17.5VAC across terminals 1 and 2.
- For commercial Fire Applications, the transformer needs to be enclosed in UL listed enclosure and conduit should be used between this enclosure & control panel.
- The minimum dimensions for this enclosure should be W4.25" x H5.625" x D2.5".

---

**3 & 4**                *Auxiliary Power Output*

- Terminal 4 is positive and terminal 3 is ground.
- For devices that require an interruption of power to perform a reset (Latching outputs), terminals 53 & 54 (Switched Aux. Power) should be used to supply power.
- A self resetting PTC protects this output.

---

**5 & 6**                *Tamper Input*

- The cabinet door must use a UL listed tamper switch to comply for UL certification.
- This input requires a Normally Closed contact.
- This input does not require an end of line resistor.

---

**6 & 57**                *Ground Inputs*

- Terminals 6 and 57 are Ground (-) inputs and may be used as the return side for powered devices, or for any device that requires a ground reference.
- Do not connect devices to these terminals that require a negative power source that "floats" above ground; i.e., the return side of a two wire smoke detector or bell input.

---

**7 & 6**                *Keyswitch Input*

- Momentary output device only.
- Examples of devices that may be used to arm the control panel are:
  1. automation systems.
  2. wireless radio receiver.
  3. light controllers.

## Wiring Data

Terminals	Description
-----------	-------------

---

<b>8 &amp; 4</b>	<b>LED 1 Output (12vdc)</b>
------------------	-----------------------------

- Terminal 8 is the negative and terminal 4 positive power.
- The voltage on this output will be present when all zones are in a secure state.
- There must be a 1K resistor wired in series with this output to prevent damage to the LED.

---

<b>9 &amp; 4</b>	<b>LED 2 Output (12vdc)</b>
------------------	-----------------------------

- Terminal 9 is the negative and terminal 4 positive power.
- The voltage on this output will be present when the control panel is in an armed state and will be pulsating should there been an alarm activation while the panel was in an armed state.
- There must be a 1K resistor wired in series with this output to prevent damage to the LED.

---

<b>10 &amp; 3</b>	<b>Auxiliary 1 Input</b>
-------------------	--------------------------

- Terminal 10 and 3 (neg.) allows for the control panel partitions to be armed with a momentary type remote arming device.

---

<b>11 &amp; 3</b>	<b>Auxiliary 2 Input</b>
-------------------	--------------------------

- Terminal 11 and 3 (neg.) allows for the control panel partitions to be armed with a momentary type remote arming device.

---

<b>12 &amp; 4</b>	<b>PGM 1 Output</b>
-------------------	---------------------

- Terminal 12 is a programmable open collector output.
- This output provides a negative voltage output that sinks to ground when activated.
- Use terminal 4 to provide the positive voltage that is necessary.
- This output is capable of providing a maximum of 50mA of current.
- Use Altronix RBSN or the Alarm Controls model 8007 relay base with an 8012 relay.
- See Chart on page 21 for wiring to relays

---

<b>13-14-15-16</b>	<b>Data, Clk, PWR, and GND (G-EX zone expander boards)</b>
--------------------	------------------------------------------------------------

- Terminals 13 OMNET Data (yellow wire)
- Terminal 15 OMNET Clock (green wire)
- Terminals 14 OMNET Positive voltage (red wire)
- Terminal 16 OMNET Ground (black wire)
- The maximum distance is 1000 ft. that the expander boards may be removed
- These terminals provide an output voltage of approximately 13.5VDC.

---

<b>17-18-19-20</b>	<b>Keypad Data and Power</b>
--------------------	------------------------------

- A total of eight (8) keypads can be connected to the system
- The voltage available across terminals 19 and 20 is approximately 13.5VDC
- A self resetting PTC protects this power output.
- The data pair (terminals 17 and 18) must be minimum #22 AWG twisted pair.
- The data pair must be terminated with an end-of-line resistor for RFI and EMI rejection, we suggest that keypads be in a daisy chain manner. (see page 13).
- 150 ohm terminating resistor is installed across the data pair at the last keypad if daisy chain.
- A terminating resistor must be placed across the data pair at each keypad if home run.
- There is a two position dip switch (S1), located within the rear access window of the keypad.
- The dip switch (S1) is used for selecting the keypads unique address.

# Wiring Data

Terminals    Description

**21 to 44    Zone Inputs 1-16**

- Quick connect terminal strips.
- The common side of each zone floats above ground.
- Normally open and/or normally closed, or a combination of both may be installed.
- Each zone may be individually programmed for supervision.
- 2.2K ohm 1/2W (EOL) (color coding red-red-red-gold).
- Each zone may also be programmed for various loop response times.
- All smoke detectors, heat detectors, water flow switches, pull station must use EOL Resistors
- For trouble shooting purposes, the zone input voltages for supervised zones (with EOL) are as follows:

<u>Electrical State</u>	<u>Voltage Readings</u>
Normal State	1.7 - 3.2 VDC
Open	3.5 - 5.0 VDC
Short	0.0 - 1.5 VDC

**45 & 46    Auxiliary Power**

- Terminal 45 is positive and terminal 46 is ground.
- For devices that require the interruption of power to perform a reset (Latching outputs), terminals 53 & 54 (Switched Aux. Power) should be used to supply power.
- A self resetting PTC protects this power output.

**47 & 48    Bell 2 Output (Unsupervised)**

- This Bell output may be steady or pulsating 12VDC on an alarm condition.
- A self resetting PTC protects this power output.

**49 & 50    Bell 1 Output (Supervised)**

- This Bell output may be steady or pulsating 12VDC on an alarm condition.
- This bell output is supervised and must be terminated with a 2.2k ohm, 1/2W EOL resistor.
- A trouble condition will be indicated on a short or open.
- A self resetting PTC protects this power output.
- The following table indicates the thresholds for the bell supervision:

<u>Resistance</u>	<u>Current</u>	<u>Voltage</u>	<u>Condition</u>
0 Ω	.18 mA	0.0 VDC	Normal
2.2K Ω	.17 mA	0.4 VDC	Normal
29.3K Ω	.13 mA	4.0 VDC	Normal*
87K Ω	.08 mA	7.4 VDC	Normal
>87K Ω	<.08mA	>7.4VDC	Trouble

\* This is the point where the bell circuit becomes normal if the circuit was in a trouble condition.

**51 & 52    Ext. Bell Pwr Supply Input**

- These terminals allow for the connection of an external power source.
- Power will be delivered to terminals 49 and 50 (supervised bell output) only.
- The external power source maybe 12 or 24 VDC @ 5 amps maximum.
- Jumper JP9 is used to select the source of bell power:
  - Removed - external supplied bell power selected (factory default).
  - Installed - panel supplied power.

## Wiring Data

**Terminals    Description**

**53 & 54      *Switched Auxiliary Power Output***

- Connect to devices that require an interruption of power to cause the devices to reset.
- Examples of latching devices - 4 wire smoke detectors, glass breaks, etc.
- A self resetting PTC protects this power output.

**55 & 56      *2-Wire Smoke Detector Input***

- This zone input requires a 2.2K ohm EOL resistor placed in parallel at the last smoke detector
- The maximum number of smoke detectors that may be installed is 10.
- Use the following table to assist in troubleshooting the 2-wire smoke detector circuit.
- When reading DC voltage you will need to place your meter probes to terminals 55 and 56.

<u>Condition</u>	<u>Voltage Reading</u>
Trouble	0.0 VDC to 0.62 VDC
Normal	0.62 VDC to 1.80 VDC
Alarm	1.80 VDC to 7.96 VDC
Trouble	7.96 VDC or greater

**58            *PGM 2 Output***

- Terminal 58 is a programmable open collector output.
- This output provides a negative voltage output that sinks to ground when activated.
- Use terminal 68 to provide the positive voltage that is necessary.
- This output is capable of providing a maximum of 50mA of current.
- Use Altronix RBSN or the Alarm Controls model 8007 relay base with an 8012 relay.
- See Chart on page 15 for wiring to relays.

**59-60-61    *Auxiliary Relay 2 Output***

- These terminals provide an auxiliary Form C relay output.
- This output is “dry”.
- The relay contacts are rated at Max 5 amp.
  - Terminal 59 - Common.
  - Terminal 60 - Normally Closed.
  - Terminal 61 - Normally Open.

**62-63-64    *Auxiliary Relay 1 Output***

- These terminals provide an auxiliary Form C relay output.
- This output is “dry”.
- The relay contacts are rated at Max 5 amp.
  - Terminal 62 - Common.
  - Terminal 63 - Normally Closed.
  - Terminal 64 - Normally Open.

**65            *Listen In Input***

- This terminal allows for the provision of a listen in amp. and will provide an audio path to the amplifier.
- Power for the amplifier should be derived from Aux. Power terminals 3(-) and 4(+) or 45(+) and 46(-). (Additional hardware required).



# Wiring Data

Terminals    Description

- 66**            *PGM 3 Output*
- Terminal 66 is a programmable open collector output.
  - This output provides a negative voltage output that sinks to ground when activated.
  - Use terminal 68 to provide the positive voltage that is necessary.
  - This output is capable of providing a maximum of 50mA of current.
  - Use Altronix RBSN or the Alarm Controls model 8007 relay base with an 8012 relay.
  - See Chart on page 15 for wiring to relays.

- 67 & 68**      *Auxiliary Power Output*
- Terminal 68 is the positive and terminal 67 is ground.
  - For devices that require the interruption of power to reset them (Latching outputs), terminals 53 & 54 (Switched Aux. Power) should be used to supply power.
  - A self resetting PTC protects this power output.

- 70-71-72**     *Long Range Radio Outputs*
- These terminals allow for the installation of the Optex Long Range Radio Transmitter, RF-RM1 that when used will provide a higher level of communication integrity.
  - Additional hardware required.
  - Compatible *only with Optex America Inc. radio system.*

- 73-74-75-76** *Teleco 2 Input*
- 73 (Ring) is the premise side.
  - 74 (Tip) is the premise side.
  - 75 (Ring) the teleco input from the phone company.
  - 76 (Tip) the teleco input from the phone company.
  - These terminals are used for connecting the control panel to an RX-31X phone jack to provide full line seizure.
  - Fault condition sensed at 4.V.

- 77-78-79-80** *Teleco 1 Input*
- 77 (Ring) is the premise side.
  - 78 (Tip) is the premise side.
  - 79 (Ring) the teleco input from the phone company.
  - 80 (Tip) the teleco input from the phone company.
  - These terminals are used for connecting the control panel to an RX-31X phone jack to provide full line seizure.
  - Fault condition sensed at 4.V.

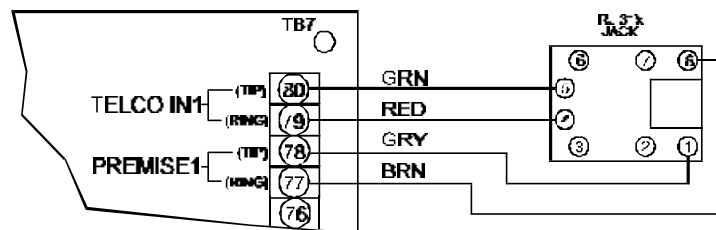

# Expansion

- The SMDC allows for the installation of up to eight (8) remote zone expansion boards.
- These zone expansion boards allow for the installation of eight individual protection devices.
- The maximum length of cable that maybe installed to wire these zone boards is 1000 feet of twenty two (22) gauge four (4) conductor.
- Each of the zone expansion boards have addressing jumpers that must be either removed or in place to allow the control panel to “talk” and identify which expansion board is issuing the command.
- The chart below indicates the proper addressing methods for each zone expansion board.
- Installation program location 2.6 must have the correct number of expander boards enabled.

## G-EX Expander Board Jumper Setting

G-EX		Zone #	J1	J2	J3
Board 1	=	Zones 17-24	Off	Off	Off
Board 2	=	Zones 25-32	Off	Off	On
Board 3	=	Zones 33-40	Off	On	Off
Board 4	=	Zones 41-48	Off	On	On
Board 5	=	Zones 49-56	On	Off	Off
Board 6	=	Zones 57-64	On	Off	On
Board 7	=	Zones 65-72	On	On	Off
Board 8	=	Zones 73-80	On	On	On

# Expansion Diagram

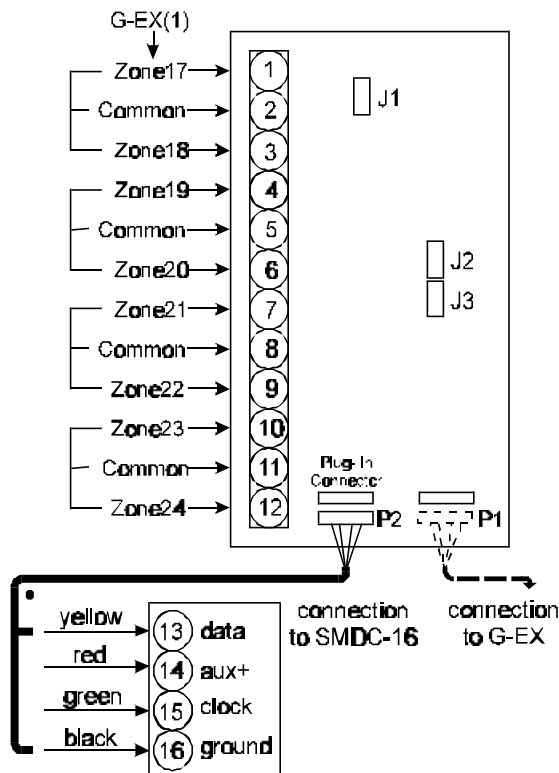

## Control Panel Hardware

Location    Description

**P1**            *Battery Connection*

- Use only a 12VDC lead acid. Use of any other battery type may cause damage.
- SMDC provides a continuous 13.6VDC to the panel under normal conditions.
- 11.45VDC, a low battery signal will be transmitted to the central station if programmed.
- 11.85VDC, the panel will transmit a battery restore code to the central station, if programmed.
- The panel will disconnect the battery 9.0 Vdc after loss of AC power
- The control panel will revert to the same operating condition once the AC power has returned.
- The SMDC control panel is protected by a self-resting PTC.
- The PTC will remain open until the polarity has been corrected and then automatically reset.

**P2**            *Keypad Connector*

- This input allows for a SMPC keypad to be easily attached to the control panel via Optex part number 5090-0194 cable assembly to program the control panel or to perform any task that would be simplified by having the keypad attached directly to the control panel.

*Relays*

- K6**            Relay used for auxiliary Relay 2. Contacts rated @ 5 amp.
- K7**            Relay used for auxiliary Relay 1. Contacts rated @ 5 amp.
- K1**            Relay used for telephone line seizure on phone line number one and two.
- K3**            Relay used for telephone line switching between phone line number one and two.
- K8**            Fire bell relay.
- K4**            Dialer relay.
- K2**            Radio output relay.

## Battery Calibration

Should there be a damaged caused to the control panel EEPROM this may cause a need to re-calibrate to SMDC control panel to accommodate your battery. You should always check the battery charging circuit with a load before the final turnover to insure proper operation. The following steps are used for the calibration process

- |                                                                                                                                                                                                                                                                                                                                                                     |                                                                                                                                                                                                                                                                                                                         |
|---------------------------------------------------------------------------------------------------------------------------------------------------------------------------------------------------------------------------------------------------------------------------------------------------------------------------------------------------------------------|-------------------------------------------------------------------------------------------------------------------------------------------------------------------------------------------------------------------------------------------------------------------------------------------------------------------------|
| <ol style="list-style-type: none"> <li>1. Enter your company PIN.</li> <li>2. Press <i>Enter</i>.</li> <li>3. The keypad will now be placed in the Volt Meter mode.</li> <li>4. Press <i>Program</i>.</li> <li>5. The keypad will display: "<i>Disconnect Battery</i>"<br/>"Press <i>Enter</i>"</li> <li>6. Disconnect battery &amp; Press <i>ENTER</i>.</li> </ol> | <ol style="list-style-type: none"> <li>7. Wait 2 seconds.</li> <li>8. Re-connect battery.</li> <li>9. Press <i>Scan</i> until the battery current is displayed.</li> <li>10. Disconnect AC.</li> <li>11. Keypad should display a negative current.</li> <li>12. Restore AC.</li> <li>13. Press <i>Clear</i>.</li> </ol> |
|---------------------------------------------------------------------------------------------------------------------------------------------------------------------------------------------------------------------------------------------------------------------------------------------------------------------------------------------------------------------|-------------------------------------------------------------------------------------------------------------------------------------------------------------------------------------------------------------------------------------------------------------------------------------------------------------------------|

# Battery Calculations

## Example

### 72 Hour Standby Plus 4 Minutes Bell Ringing

<u>Equipment (Non Alarm)</u>	<u>Current (ea.)</u>	X	<u># of Hours</u>	X	<u># of Units</u>	=	<u>Total Ah</u>
SMDC-16	<u>.113 A</u>	X	<u>72</u>	X	<u>1</u>	=	<u>8.136</u>
SMPC-32 D	<u>.070 A</u>	X	<u>72</u>	X	<u>1</u>	=	<u>5.04</u>
SMPC-32 DL	<u>.095 A</u>	X	<u>72</u>	X	<u>1</u>	=	<u>6.840</u>
GEX	<u>.029 A</u>	X	<u>72</u>	X	<u>2</u>	=	<u>4.176</u>
2 wire smoke detectors	_____	X	_____	X	_____	=	_____
Switched Aux Power	_____	X	_____	X	_____	=	_____
Aux. Power	_____	X	_____	X	_____	=	_____
						(1) ttl	<u>24.192</u>
<u>Equipment (In Alarm)</u>	<u>Current (ea)</u>	X	<u># of Hours</u>	X	<u># of Units</u>	=	<u>Total Ah</u>
SMDC-16	<u>.290 A</u>	X	<u>4 min ÷ 60</u>	X	<u>1</u>	=	<u>0.019</u>
SMPC-32 D	<u>.111 A</u>	X	<u>4 min ÷ 60</u>	X	<u>1</u>	=	<u>0.007</u>
SMPC-32 DL	<u>.140 A</u>	X	<u>4 min ÷ 60</u>	X	<u>1</u>	=	<u>0.009</u>
G-EX	<u>.029 A</u>	X	_____	X	_____	=	<u>0.004</u>
2 wire smoke detector	_____	X	_____	X	_____	=	_____
Switched Aux. Power	_____	X	_____	X	_____	=	_____
Aux. Power	_____	X	_____	X	_____	=	_____
Indicating Device (bells, etc)	<u>.500A</u>	X	<u>4 min ÷ 60</u>	X	<u>1</u>	=	<u>0.033</u>
						(2) ttl	<u>0.072</u>
						(1+2) ttl	<u>24.264</u>
						multiply by derating factor of 1.2 total	<u>29.117</u>

A suitable battery for 72 hour standby is **12vdc 33 amp hour**

## Work Sheet

### 72 Hour Standby Plus 4 Minutes Bell Ringing

<u>Equipment (Non Alarm)</u>	<u>Current (ea)</u>	X	<u># of Hours</u>	X	<u># of Units</u>	=	<u>Total Ah</u>
SMDC-16	<u>.113 A</u>	X	<u>72</u>	X	_____	=	_____
SMPC-32 D	<u>.070 A</u>	X	<u>72</u>	X	_____	=	_____
SMPC-32 DL	<u>.095 A</u>	X	<u>72</u>	X	_____	=	_____
GEX	<u>.029 A</u>	X	<u>72</u>	X	_____	=	_____
2 wire smoke detectors	_____	X	<u>72</u>	X	_____	=	_____
Switched Aux Power	_____	X	<u>72</u>	X	_____	=	_____
Aux. Power	_____	X	<u>72</u>	X	_____	=	_____
						(1) ttl	_____
<u>Equipment (In Alarm)</u>	<u>Current (ea)</u>	X	<u># of Hours</u>	X	<u># of Units</u>	=	<u>Total Ah</u>
SMDC-16	<u>.290 A</u>	X	<u>4 min ÷ 60</u>	X	_____	=	_____
SMPC-32 D	<u>.111 A</u>	X	<u>4 min ÷ 60</u>	X	_____	=	_____
SMPC-32 DL	<u>.140 A</u>	X	<u>4 min ÷ 60</u>	X	_____	=	_____
GEX	<u>.029 A</u>	X	<u>4 min ÷ 60</u>	X	_____	=	_____
2 wire smoke detector	_____	X	<u>4 min ÷ 60</u>	X	_____	=	_____
Switched Aux. Power	_____	X	<u>4 min ÷ 60</u>	X	_____	=	_____
Aux. Power	_____	X	<u>4 min ÷ 60</u>	X	_____	=	_____
Indicating Device (bells, etc)	<u>.500A</u>	X	<u>4 min ÷ 60</u>	X	_____	=	_____
						(2) ttl	_____
						(1+2) ttl	_____
						multiply by derating factor of 1.2	total _____

# Keypad Functions

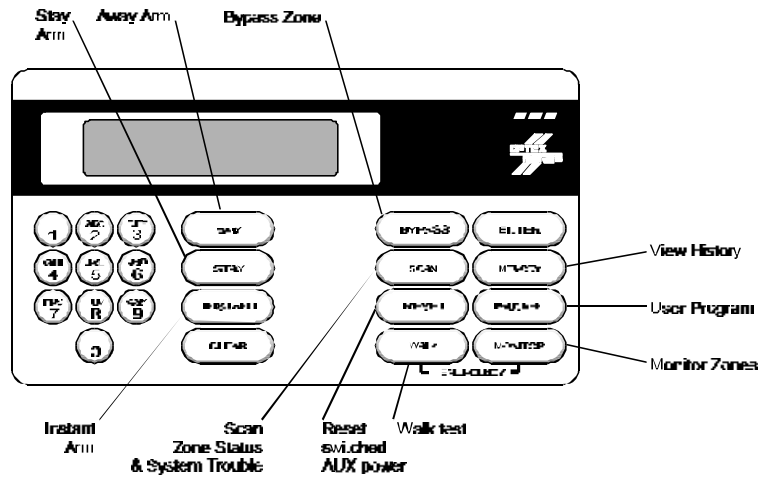

# Keypad Wiring

The following diagrams show the two methods available for the wiring of keypads, the termination resistor placement for both methods and the keypad addressing.

## Home Run Wiring

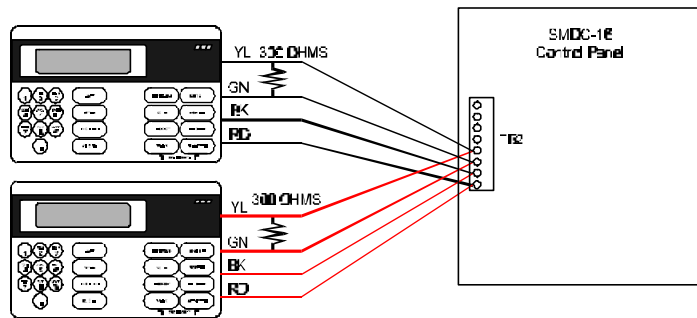

## Daisy Chain Wiring

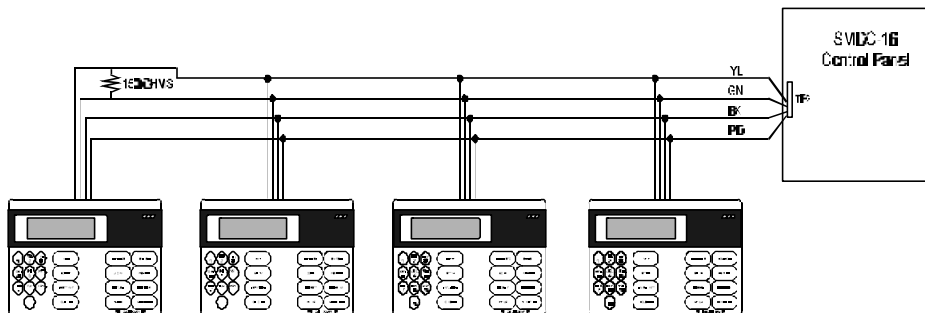

# Keypad Hardware

## SMPC-32 D /DL Keypad Connections

SMPC-32 Connection	Wire Color	SMDC Terminal
Keypad +	Red	20
Keypad -	Black	19
Keypad Data	Green	18
Keypad Data	Yellow	17

1 keypad = 150 ohms ¼ watt  
 2 keypads = 300 ohms ¼ watt  
 3 keypads = 450 ohms ¼ watt  
 4 keypads = 600 ohms ¼ watt

5 keypads = 750 ohms ¼ watt  
 6 keypads = 900 ohms ¼ watt  
 7 keypads = 1050 ohms ¼ watt  
 8 keypads = 1240 ohms ¼ watt

## Keypad Address Switch (S1) Settings

SWITCH (S1)	A	B
1 <sup>st</sup> Keypad	Off	Off
2 <sup>nd</sup> Keypad	On	Off
3 <sup>rd</sup> Keypad	Off	On
4 <sup>th</sup> Keypad	On	On

### Expanded Address Keypads

5 <sup>st</sup> Keypad	Off	Off
6 <sup>nd</sup> Keypad	On	Off
7 <sup>rd</sup> Keypad	Off	On
8 <sup>th</sup> Keypad	On	On

## Keypad Rear Access Window

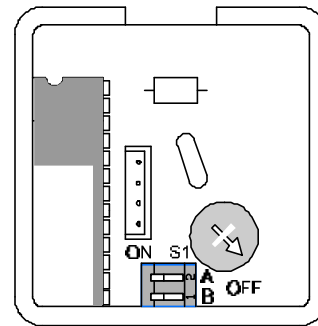

# Keypad Voltmeter

The SMDC control panel allows for the installer to check the control panel system voltages with the information to be displayed on the LCD. The voltage voltages and currents that will be displayed when the installers PIN and ENTER is depressed is:

- Bell Sense voltage.
- Battery current.
- Battery voltage.
- Switched auxiliary voltage
- 2 Wire smoke detector voltage.
- Buss voltage.
- Ground fault voltage.
- Telephone line status.

When a negative battery current reading is displayed and the AC is removed, this is the total current draw on the panel.  
 When positive battery current reading is displayed and the AC power is applied this is the charging circuit for the battery.

# PGM Trigger Wiring

Relay Module Wiring Diagram

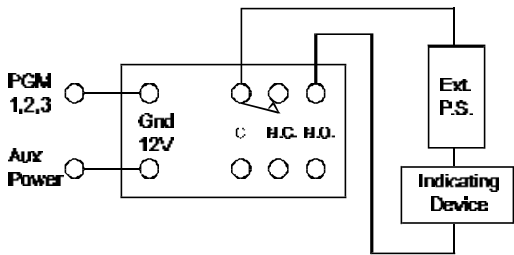

PGM Used For Ground Start Wiring Diagram

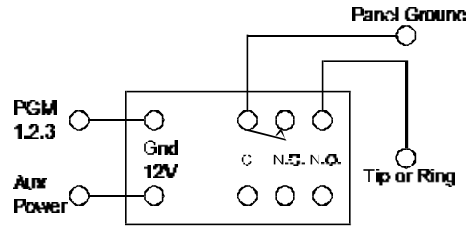

PGM outputs are low current transistor outputs that are held above ground. Once these outputs are triggered they sink to ground and supply a 50 mA output maximum.

**Warning:** pulling an excess of 50mA runs the risk of damaging these outputs.

# Appendix A

- For Installation Instructions, see Installation Manual, Part No. 3440-0251.
- Use a UL Listed End of the Line Relay for 4 wire smoke detectors.
- This control unit should be checked by a qualified technician at least every 3 years.
- This equipment should be installed in accordance with Chapter 2 of the National Fire Alarm code ANSI/NFPA 72-1993 (National Fire Protection Association, Batterymarch Park, Quincy, MA 02269). Printed information describing proper installation, operation, testing, maintenance, evacuation planning and repair service is to be provided with this equipment.
- Maximum Battery Charging Current is 700 mA.
- Type of Service: Automatic Fire Alarm, Manual Fire Alarm, Water Flow Alarm, Sprinkler Supervisory.
- Type of Signaling: Digital Alarm Communicator Transmitter. (RF using Optex-Morse Model RF-RM1 transmitter).
- The SMDC-WX (wireless features) have not been investigated for use in UL Listed Fire Applications or UL Listed Burglar Applications.
- The SMDC-INT-P/F (fax and printer options) are not for Commercial Fire Applications.
- The SMDC-INT Board connections are limited to same room.

This unit includes verification feature that will result in a delay of the system alarm signal from the indicated circuits. The total delay (Control Unit plus smoke detectors) shall not exceed 60 seconds. No other smoke detector shall be connected to these circuits unless approved by the Local Authority Having Jurisdiction.

Circuit (Zone)	Control unit delay, seconds	Smoke detector	
		Model	Delay, seconds
a. Include detector data or the following or equivalent statement. "The delay (power-up) (start-up) time marked on the installation wiring diagram of the smoke detector or on the installed smoke detector(s) is to be used.			

## Appendix B

Zone Type	Description
<b>1. Entry / Exit</b>	1) Away mode - this zone is always delayed (entry / exit). 2) Stay mode - this zone is always delayed (entry / exit). 3) Instant mode - this zone is always delayed exit and always instant alarm on entry.
<b>2. Perimeter Instant</b>	1) Away mode - this zone is always an instant alarm. 2) Stay mode - this zone is always an instant alarm. 3) Instant mode - this zone is always an instant alarm.
<b>3. Interior 1</b>	1) Away mode - this zone responds as a follower.* 2) Stay mode - this zone responds as a follower. * 3) Instant mode - this zone responds as an instant alarm if activated.
<b>4. Interior 2</b>	1) Away mode - this zone responds as a follower. * 2) Stay mode - this zone is always bypassed. 3) Instant mode - this zone is always bypassed.
<b>5. Interior 3</b>	1) Away mode - this zone is always delayed. 2) Stay mode - this zone is always delayed. 3) Instant mode - this zone is always bypassed
<b>6. 24 Hour</b>	1) This zone type is used for devices that will create an alarm regardless of the armed state of the SMDC.
<b>7. Fire</b>	1) This type of zone may also be enable for Fire Supervisory after the YES has been programmed. 2) If YES is selected for Fire Supervisory, the keypad(s) will emit a steady tone on an alarm condition and display the zone in alarm.
<b>8. Day Zone</b>	1) <i>Disarmed</i> - an activation creates an trouble condition. 2) <i>Armed</i> - an activation creates an instant alarm condition.
<b>9. Garage Door</b>	1) This zone type allows the zone to be open when arming the SMDC. 2) When the zone restores, it is returned as an active entry delay zone. 3) The zone must restore to a secure condition prior to exit delay time expiring. 4) Should the zone fail to secure, an exit error code will be transmitted if so programmed. 5) <b><i>An alarm will be generated if the zone is left open.</i></b>

\* Note: The term follower is defined as the zone will be delayed on entry if the Exit door is sensed by the control panel first, should the follower zone be sensed first by the control panel, the follower zone will create an alarm instantly.

## UL Information Addendum

### Equipment

The following equipment has been listed by Underwriters Laboratories:

- Control Panel Model SMDC-16.
- Expansion Board, Model G-EX.
- Keypad, Model SMPC-32 D/ SMPC-32 DL.



## Communication

This unit has been tested with:

- Varitech Model V-300, Receiver Using 3/1, 4/1, 4/2 Pulsed communication formats and Varitech 4-2 FSK Communication format and found to be compatible.
- This unit has been tested with Sur-Gard Model SG-DRL2A, Receiver using 4-1 pulsed communication format, 4-2 pulsed communication format, SIA LEVEL 1 communication format and Contact ID communication format and found to be compatible.

## Grades Of Service

- The unit is suitable for Police Station connect, GRADE A, Mercantile Premises and Mercantile Safe and Vault, service if used in conjunction with Model MDC-16CCS attack proof enclosure and a Listed GRADE A, local sounding device.
- The unit is suitable for Local, GRADE A, Mercantile Premises and Mercantile Safe and Vault, service if used in conjunction with Model MDC-16CCS attack proof enclosure and a listed, GRADE A, local sounding device.
- The unit is suitable for Central Station, GRADE C, service if used in conjunction with Model MDC-16CCS attack proof enclosure.
- The unit is suitable for Central Station, Grade B, service if used in conjunction with Model MDC-16CCS attack proof enclosure and a Listed, Grade A, local sounding device.

## UL Listings

- UL 1023 - Household Burglar-Alarm System Units.
- UL 985 - Household Fire Warning System Units.
- UL 1610 - Central-Station Burglary-Alarm Units.
- UL 1635 - Digital Alarm Communicator System Units.
- UL 365 - Police Station Connected Burglar Alarm Units And Systems.
- UL 609 - Local Burglar Alarm Units And Systems.
- UL864 - Control Units for Fire-Protective Signaling Systems.

## For Grade A Local Mercantile Installations

- The minimum requirements to form a listed Grade A local System includes:
  1. Low Battery Alarm condition (Unless dialer used to transmit a low battery message).

## Current Rating Chart

- |                        |   |        |
|------------------------|---|--------|
| • Control SMDC-16      | = | 113 MA |
| • Keypad SMPC-32D      | = | 70 MA  |
| • Keypad SMPC-32 DL    | = | 95 MA  |
| • Expansion Board G-EX | = | 29 MA  |

## Walk Test

It is imperative to perform a Walk Test after the initial installation of the system. The Walk Test allows you to test all burglary type zones. Zone option for Walk Test (menu 2.1.7.7.) must be selected for each of these zones.

To initiate the Walk Test mode:

- The Central Station and subscriber *must* be notified of this test as the communicator will also be tested by transmitting alarm signals as well as the audible devices on all 24 Hour and Day zones.
- Press the **WALK** key.
- Enter your installer PIN.
- Press **1** button on keypad to select **WALK TEST**.
- Once the Walk Test is initiated, all zones programmed for Walk Test will scroll on the keypad.
- Each time a zone is activated the keypad will emit an audible tone send a signal (if it is a 24 hour type zone programmed for reporting), tripped the audibles (if it is a 24 hour type zone programmed to activate voltages, relays, etc.) eliminate that zone from scroll list and return to scrolling the remainder of zones that need to be tested.
- After all zones have been tested, the keypad will display “**WALK TEST DONE**” on the keypad display.
- Press **CLEAR** key to exit Walk Test Mode.

## Fire Test Mode

It is imperative to perform a Fire Walk Test after the initial installation of the system. The Fire Walk Test allows you to test all zones that have been programmed as a Fire zone in the installers program (menu 2.1.1.). Zone option for Walk Test (menu 2.1.7.7.) must be selected for each of these zones.

To initiate the Fire Walk Test mode:

- The Central Station and subscriber *must* be notified of this test as the communicator will also be tested by transmitting alarm signals as well as the audible devices will also be tested.
- Press **WALK** button.
- Enter your installers PIN.
- Press **2** button on keypad to select **FIRE WALK TEST**.
- Once the Fire Walk Test is initiated, all fire zones programmed for Walk Test will scroll on the keypad.
- Each time a zone is activated, the keypad will emit an audible tone, send a signal (if programmed for reporting), tripped the audibles (if programmed to activate voltages, relays, etc.) eliminate that zone from scroll list and return to scrolling the remainder of zones that need to be tested.
- The control panel will automatically reset the power for both the 2-wire smoke detector circuit and the switched auxiliary power allowing for the activation of subsequent devices with out the need to return to a keypad and performing a power reset
- After all zones have been tested, keypad will display “**WALK TEST DONE**” message on keypad.
- Press **CLEAR** key to exit Walk Test

## Walk Test History

Walk Test history allows the installation company to view the activation's of both the Burglary and the Fire Walk test history in the same sequence of activation's that have occurred. To view the walk test history:

- Press the **WALK** key.
- The display will ask for a PIN number.
- Enter your Installer Pin Number.
- Display will scroll three choices.
- Press **3** key on keypad to select **WALK TEST HISTORY**.
- The first zone that tripped will be on the display, to view subsequent activation's press the **SCAN** button.
- After the last zone that was activated is scanned, the keypad will revert back to the Walk Test options.
- The Walk test history will be retained in the memory until another walk test is performed regardless of the arming and disarming of the control panel.

## UL Compliance Verification Chart

### Compatible Bell/Horn/Strobe

MFG	MODEL #	DEVICE TYPE	MFG	MODEL #	DEVICE TYPE
Wheelock	MB-G6-12-R	Motor Bell	Wheelock	MB-G10-12-R	Motor Bell
Wheelock	MBS-G6-12-W-HF-R	Motor Bell With Strobe	Wheelock	MBS-G10-12-W-HF-R	Motor Bell With Strobe
Wheelock	MIZ-12-R	Mini- Horn	Wheelock	MIZ-12-W	Mini-Horn
Wheelock	MIZ-12-WS-VF-R	Mini Horn/Strobe	Wheelock	V7001T-W-FR	Strobe Horn
Wheelock	WST-12-FR	Strobe	Wheelock	WS1T-12-FR	Strobe
Wheelock	WS3T-12-FR	Strobe	Wheelock	46T-G10-12-R	Bell
Amseco	MSB-10B-PV4-12	Motor Bell			

## Compatible 2-Wire Smoke Detectors

<u>Mfg</u>	<u>Model #</u>	
Detection Systems	DS250/DS250TH	Detector Identifier = A
System Sensor	2400 /2400 TH	Detector Identifier = A
Sentrol	429 C/429 CT	Detector Identifier = S10A
System Sensor	2300 T	Detector Identifier = A

## Compatible 4-Wire Smoke Detectors

The operating voltage range for 4-wire smoke detector is 9.7 - 13.7 Volts

<u>Mfg</u>	<u>Model #</u>
System Sensor	1112, 2112, 2112T, 2112TSRB
ESL	449 AT/ 449 CT, 741 U/ 741 UT
Detection Systems	DS 250 /250 TH used with MB4W base

## Program Requirements

When programming the SMDC-16, the following programs must be maintained to meet minimum UL requirements for Household Burglar Systems and/or Commercial Burglar Alarm Systems and Police Connect.

- Exit time should not exceed 60 seconds.
- Entrance time should not exceed 45 seconds including pre-alarm delay.
- Loop response not to exceed 1 second.
- Bell and/or Siren - 4 minutes minimum to meet UL Residential Burglar & Fire.
- Bell and/or Siren - 15 minutes minimum to meet UL Commercial Burglar Alarm and Police Connect.
- For the Fire Bell to ring in Temporal Pattern the following settings must be entered:
  1. Zone Type must be set to Fire Zone (menu 2.1.1).
  2. Bell 1 must be set to **YES** (menu 2.8.1).
  3. Bell 1 Pulse must be set to **YES** (menu 2.8.2).
  4. Temporal Fire must be set to **YES** (menu 4.9).
- Burglar Alarm Loops must alarm in open or shorted conditions.
- Low Battery must be programmed to report.
- Two separate phone numbers (rcvr 1 & rcvr 2) must be programmed to meet Commercial Fire Applications.
- Close Ringback must be program **YES**.
- Abnormal Self Test code must be programmed.

## Warranty

- 1 Optex equipment is warranted to be free from defects in workmanship or materials for a period of one (1) year from date of shipment to the original purchaser. No equipment may be returned without express written approval of after a determination by that such equipment is defective because of poor workmanship or defective materials. Optex shall replace or repair, at its sole and exclusive option, such defective materials or parts thereof at its own expense, except that Purchaser shall pay all shipping, insurance, and similar charges incurred in connection with the replacement of the defective equipment or parts thereof. This warranty is void in case of abuse, abnormal usage, faulty installation or repair by unauthorized persons, acts of God, or if for any other reason Optex determines that such equipment is not operating properly as a result of causes other than poor workmanship or defective materials.
- 2 Equipment not manufactured by Optex is subject solely to the terms and conditions of the manufacturer's warranty, if any, applicable to such equipment.
- 3 THE AFORESAID WARRANTIES ARE EXPRESSLY MADE IN LIEU OF ANY OTHER WARRANTIES, EXPRESS OR IMPLIED, IT BEING UNDERSTOOD THAT ALL SUCH OTHER WARRANTIES, EXPRESS OR IMPLIED, INCLUDING WARRANTIES OF MERCHANTABILITY AND FITNESS FOR PARTICULAR PURPOSE OR HEREBY EXPRESSLY EXCLUDED. IN NO EVENT SHALL OPTEX BE LIABLE TO THE PURCHASER FOR ANY DIRECT, COLLATERAL, INCIDENTAL OR CONSEQUENTIAL DAMAGE IN CONNECTION WITH PURCHASER'S USE OF THE EQUIPMENT, OR FOR ANY OTHER CAUSE WHATSOEVER RELATING TO THE EQUIPMENT.

---

### **WAIVER AND MODIFICATIONS:**

No waiver or modifications of any of the foregoing terms and conditions of sale or limited warranty policy shall be effective unless such waiver or modification is in writing and signed by an authorized representative of Optex.

---

### **TERMS AND CONDITIONS TO PREVAIL:**

The foregoing Terms and Conditions shall prevail notwithstanding any variance with any Purchase Order or other document submitted by the Purchaser for the equipment and regardless of whether or not the equipment was delivered to the Purchaser thereunder.

Any shipment made by Optex shall be in reliance upon Purchaser's acceptance of Optex Terms and Conditions as aforesaid and may not be interpreted as an acceptance or an offer to contract on the basis of any Purchaser's Terms and Conditions.